

Verder HI-CLEAN VA-H20 Diaphragm Pumps

819.0416

Rev. G
EN

For use in sanitary applications. For professional use only.



Important Safety Instructions

Read all warnings and instructions in this manual. Save these instructions.

6.9 bar (0.7 MPa, 100 psi) Maximum Fluid Working Pressure

6.9 bar (0.7 MPa, 100 psi) Maximum Air Input Pressure

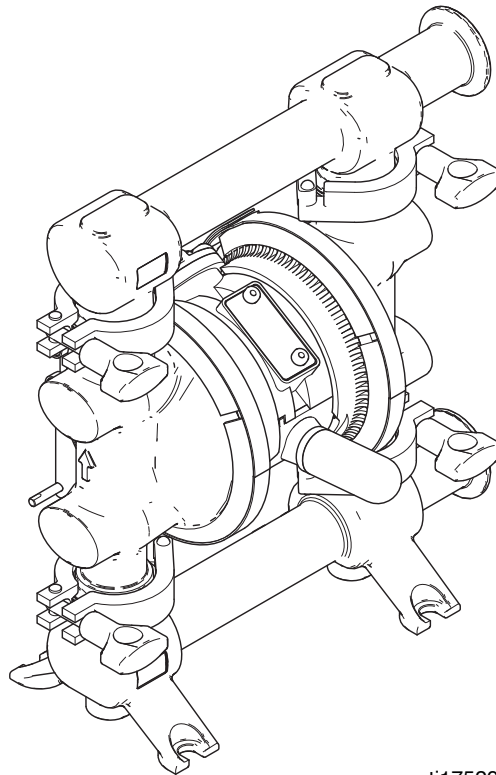

ti17529a



II 2 GD c IIA T4

Contents

Models	3	Maintenance	12
Available Configurations	3	Air Valve Lubrication	12
Warnings	4	Flushing	12
Installation	6	Tightening Connections	12
General Information	6	Preventive Maintenance Schedule	12
Tighten Clamps Before First Use	6	Troubleshooting	13
Grounding	6	Service	14
Mounting	7	Air Valve	14
Air Line	7	Ball Check Valve	16
Fluid Suction Line	7	Standard Diaphragms	16
Fluid Outlet Line	8	Overmolded PTFE Diaphragms	18
Changing the Orientation of the Fluid Inlet and Outlet Ports	9	Air Center Service	19
Air Exhaust Ventilation	10	Parts	20
Operation	11	Fluid Section Repair Kits*	22
Pressure Relief Procedure	11	Dimensions	23
Sanitize the Pump Before First Use	11	Performance Charts	24
Starting and Adjusting the Pump	11	Technical Data	26
Pump Shutdown	11	Customer Services/Guarantee	31

Models

Sample Configuration Number: VA-H20 SP ST TF TF T2 FD





VA-H	20	SP	ST	TF	TF	T2	FD
Pump Model	Size	Fluid Section and Air Section	Seats and O-Rings	Balls	Diaphragms	Connections	Pump Style

Some combinations are not possible. Please check with your local supplier or the pump configurator on www.verderair.com.

Pump Model	Fluid Section and Air Section Material		Seats and O-Rings		Check Valve Balls	
VA-H20	SP	Stainless Steel Pump with Polypropylene Air Section	SE	Stainless Steel Seats with EPDM O-Rings	SP	Santoprene
			ST	Stainless Steel Seats with PTFE O-Rings	TF	PTFE





Diaphragm		Connections		Pump Style	
SP	Santoprene	D2	DIN 11851, 25 mm	FD	FDA
TF	PTFE/TPE 2-Piece	T2	Tri-clamp, 1 in.		
TO	PTFE Overmolded				

Available Configurations

Model	Configuration Number	Approvals
810.0824	VA-H20 SP ST TF TF T2 FD	 EC 1935/2004 Compliant
810.0825	VA-H20 SP ST TF TF D2 FD	
810.0826	VA-H20 SP ST TF TO T2 FD	
810.0827	VA-H20 SP ST TF TO D2 FD	  II 2 GD c IIA T4
810.0828	VA-H20 SP SE SP SP T2 FD	  II 2 GD c IIA T4
810.0829	VA-H20 SP SE SP SP D2 FD	

Warnings

The following warnings are for the setup, use, grounding, maintenance, and repair of this equipment. The exclamation point symbol alerts you to a general warning and the hazard symbols refer to procedure-specific risks. When these symbols appear in the body of this manual or on warning labels, refer back to these Warnings. Product-specific hazard symbols and warnings not covered in this section may appear throughout the body of this manual where applicable.

 WARNING	
	<p>FIRE AND EXPLOSION HAZARD</p> <p>Flammable fumes, such as solvent and paint fumes, in work area can ignite or explode. To help prevent fire and explosion:</p> <ul style="list-style-type: none"> • Use equipment only in well ventilated area. • Eliminate all ignition sources; such as pilot lights, cigarettes, portable electric lamps, and plastic drop cloths (potential static arc). • Keep work area free of debris, including solvent, rags and gasoline. • Do not plug or unplug power cords, or turn power or light switches on or off when flammable fumes are present. • Ground all equipment in the work area. See Grounding instructions. • Use only grounded hoses. • Hold gun firmly to side of grounded pail when triggering into pail. Do not use pail liners unless they are antistatic or conductive. • Stop operation immediately if static sparking occurs or you feel a shock. Do not use equipment until you identify and correct the problem. • Keep a working fire extinguisher in the work area.
	<p>TOXIC FLUID OR FUMES HAZARD</p> <p>Toxic fluids or fumes can cause serious injury or death if splashed in the eyes or on skin, inhaled, or swallowed.</p> <ul style="list-style-type: none"> • Read MSDS's to know the specific hazards of the fluids you are using. • Route exhaust away from work area. If diaphragm ruptures, fluid may be exhausted into the air. • Store hazardous fluid in approved containers, and dispose of it according to applicable guidelines.
	<p>PRESSURIZED EQUIPMENT HAZARD</p> <p>Fluid from the equipment, leaks, or ruptured components can splash in the eyes or on skin and cause serious injury.</p> <ul style="list-style-type: none"> • Follow the Pressure Relief Procedure when you stop spraying/dispensing and before cleaning, checking, or servicing equipment. • Tighten all fluid connections before operating the equipment. • Check hoses, tubes, and couplings daily. Replace worn or damaged parts immediately.



WARNING



EQUIPMENT MISUSE HAZARD

Misuse can cause death or serious injury.

- Do not operate the unit when fatigued or under the influence of drugs or alcohol.
- Do not exceed the maximum working pressure or temperature rating of the lowest rated system component. See **Technical Data** in all equipment manuals.
- Use fluids and solvents that are compatible with equipment wetted parts. See **Technical Data** in all equipment manuals. Read fluid and solvent manufacturer's warnings. For complete information about your material, request MSDS from distributor or retailer.
- Do not leave the work area while equipment is energized or under pressure.
- Turn off all equipment and follow the **Pressure Relief Procedure** when equipment is not in use.
- Check equipment daily. Repair or replace worn or damaged parts immediately with genuine manufacturer's replacement parts only.
- Do not alter or modify equipment. Alterations or modifications may void agency approvals and create safety hazards.
- Make sure all equipment is rated and approved for the environment in which you are using it.
- Use equipment only for its intended purpose. Call your distributor for information.
- Route hoses and cables away from traffic areas, sharp edges, moving parts, and hot surfaces.
- Do not kink or over bend hoses or use hoses to pull equipment.
- Keep children and animals away from work area.
- Comply with all applicable safety regulations.



BURN HAZARD

Equipment surfaces and fluid that's heated can become very hot during operation. To avoid severe burns:

- Do not touch hot fluid or equipment.



PERSONAL PROTECTIVE EQUIPMENT

Wear appropriate protective equipment when in the work area to help prevent serious injury, including eye injury, hearing loss, inhalation of toxic fumes, and burns. This protective equipment includes but is not limited to:

- Protective eyewear and hearing protection.
- Respirators, protective clothing, and gloves as recommended by the fluid and solvent manufacturer.

Installation

General Information

- The typical installation shown in FIG. 2, page 8, is only a guide for selecting and installing system components. Contact your Verder representative for assistance in planning a system to suit your needs.
- Reference numbers and letters in parentheses refer to the callouts in the figures.

<p>The pump is heavy and may cause injury if dropped. Lift the pump by grasping the outlet manifold securely.</p> <p>If dropped, the pump may rupture. To avoid serious injury from splashing fluid, follow the Pressure Relief Procedure on page 11 before moving the pump.</p>						

<p>To reduce the risk of serious injury due to burns, insulate the pump before pumping hot fluids.</p>						

Tighten Clamps Before First Use

After you unpack the pump, and before you use it for the first time, check all clamps and tighten as necessary.

Grounding

<p>The equipment must be grounded. Grounding reduces the risk of static and electric shock by providing an escape wire for the electrical current due to static build up or in the event of a short circuit.</p>						

- **Pump:** Attach a ground wire (Y) to the grounding strip (8) with the screw (9a), lockwasher (9b), and nut (9c), as shown in FIG. 1, and per local code. Connect the clamp end of the ground wire to a true earth ground. Order ground wire Part Number 819.0673.

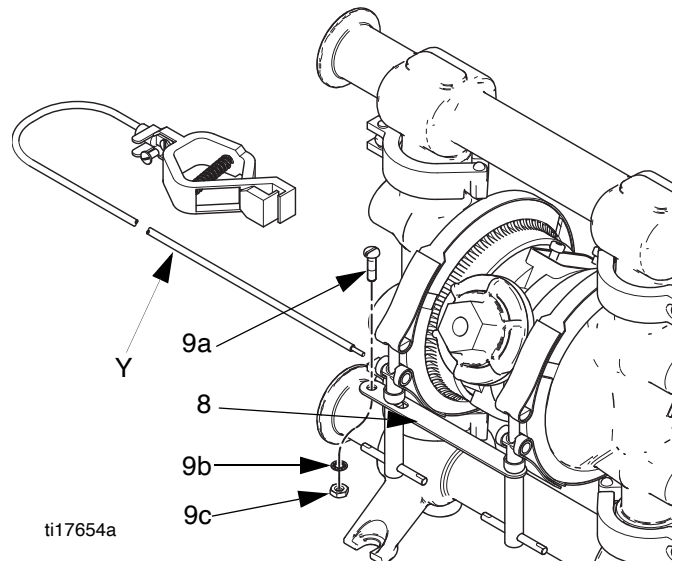

FIG. 1: Ground the pump

- **Fluid hoses:** Use only grounded hoses with a maximum of 150 m (500 ft) combined hose length to ensure grounding continuity.
- **Air compressor:** Follow the manufacturer's recommendations.
- **All solvent pails used when flushing:** Follow the local code. Use only metal pails, which are conductive. Do not place the pail on a non-conductive surface, such as paper or cardboard, which interrupts the grounding continuity.
- **Fluid supply container:** Follow the local code.

Mounting

NOTICE

Pump exhaust air may contain contaminants that can contaminate the fluid supply. Ventilate to a remote area. See **Air Exhaust Ventilation** on page 10.

- Be sure the mounting surface can support the weight of the pump, hoses, and accessories, as well as the stress caused during operation.
- For all mountings, be sure the pump is bolted directly to the mounting surface.
- For ease of operation and service, mount the pump so the air valve cover, air inlet, and fluid inlet and outlet ports are easily accessible.

Air Line



Trapped air can cause the pump to cycle unexpectedly, which could result in serious injury, including splashing in the eyes or on the skin, injury from moving parts, or contamination from hazardous fluids. A bleed-type master air valve (B) is required in the system to relieve air trapped between this valve and the pump.

See FIG. 2, page 8.

1. Install the air line accessories as shown in FIG. 2. Mount these accessories on the wall or on a bracket. Be sure the air line supplying the accessories is grounded.
 - a. Install an air regulator/filter assembly (C) and gauge to control the fluid pressure. The fluid outlet pressure will be the same as the setting of the air regulator. The air line filter removes harmful dirt and moisture from the compressed air supply.
 - b. Locate one bleed-type master air valve (B) close to the pump and use it to relieve trapped air. See the **WARNING** above. Locate the other master air valve (E) upstream from all air line accessories and use it to isolate them during cleaning and repair.



In the step below, do not connect the quick-disconnect coupler (D) on the air hose to the mating fitting on the pump until you are ready to operate the pump. Connecting the coupler too early can result in unintentional operation of the pump, leading to serious injury from moving parts, splashing fluid in the eyes or on the skin, and contact with hazardous fluids.

2. Install a grounded, flexible air hose (A) between the accessories and the 1/4 npt(f) pump air inlet. Use a minimum 6.3 mm (1/4 in) ID air hose. Screw an air line quick disconnect coupler (D) onto the end of the air hose (A), and screw the mating fitting into the pump air inlet snugly.

Fluid Suction Line

1. Use flexible, grounded fluid hoses (F). The inlet fits sanitary tubing of 1 to 1.5-inch OD.
2. For best sealing results, use an appropriate tri-clamp-style or DIN-style sanitary gasket of a flexible material such as EPDM or Buna-N.
3. If the fluid inlet pressure to the pump is more than 25% of the outlet working pressure, the ball check valves will not close fast enough, resulting in inefficient pump operation. Excessive inlet fluid pressure also will shorten diaphragm life. Approximately 0.21-0.34 bar (0.02 - 0.03 MPa, 3 - 5 psi) should be adequate for most materials.
4. For maximum suction lift (wet and dry), see **Technical Data**, page 26. For best results, always install the pump as close as possible to the material source.

Fluid Outlet Line

--	--	--	--	--	--	--

A fluid drain valve (G) is required to relieve pressure in the hose if it is plugged. The drain valve reduces the risk of serious injury, including splashing in the eyes or on the skin, or contamination from hazardous fluids when relieving pressure.

1. Use flexible grounded fluid hoses (J).
2. For best sealing results, use an appropriate standard tri-clamp-style or DIN-style sanitary gasket of a flexible material such as EPDM or Buna-N.
3. Install a fluid drain valve (G) near the fluid outlet. See FIG. 2.
4. Install a shutoff valve (H) in the fluid outlet line.

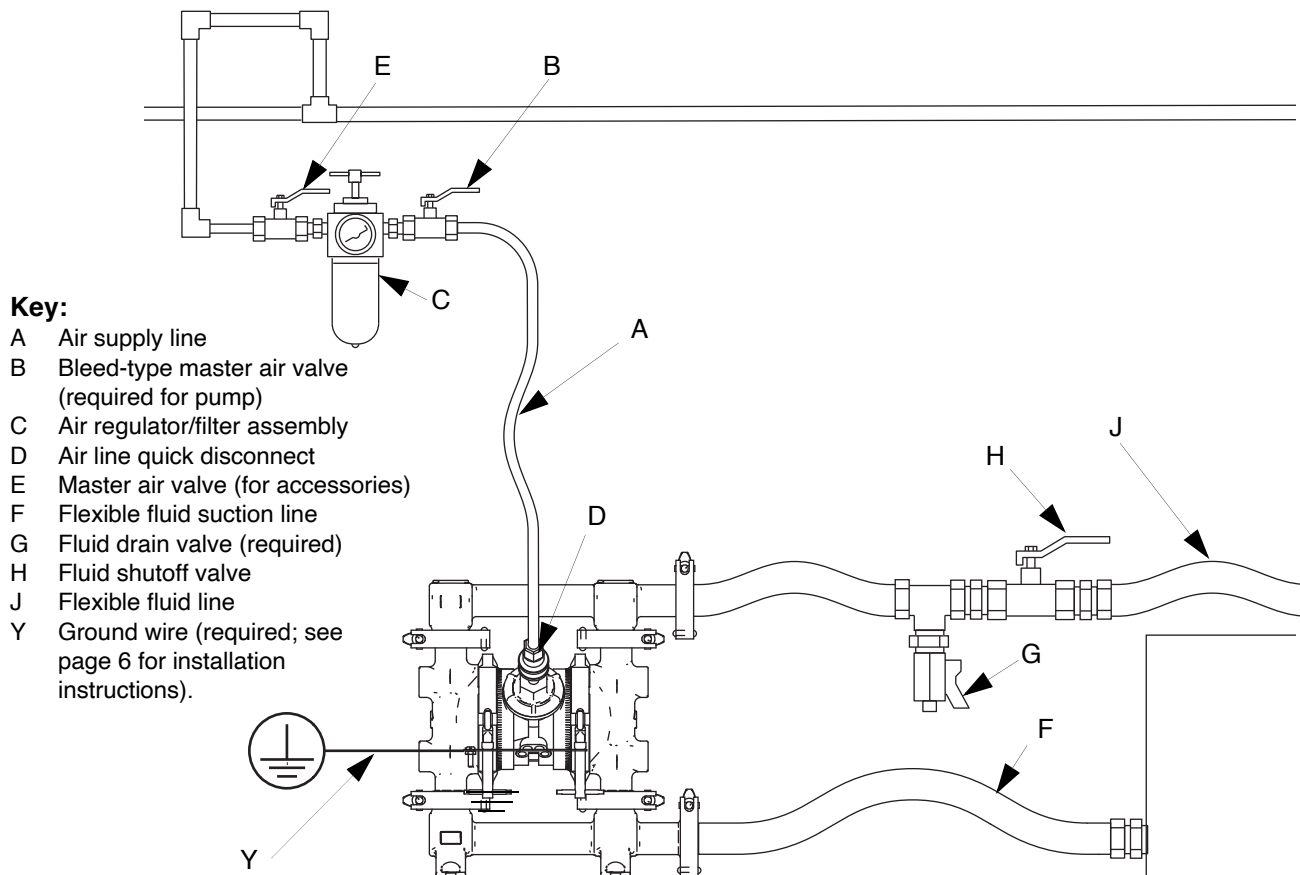

ti17652a

FIG. 2: Typical Floor-Mount Installation

Changing the Orientation of the Fluid Inlet and Outlet Ports

The pump is shipped with the ports facing the same direction. To reverse the orientation of the ports:

1. Remove the clamps (12) holding the inlet and/or outlet manifold to the covers.

NOTE: Inspect the o-rings and replace if necessary.

2. Reverse the manifold and reattach. Install and tighten clamps snugly.

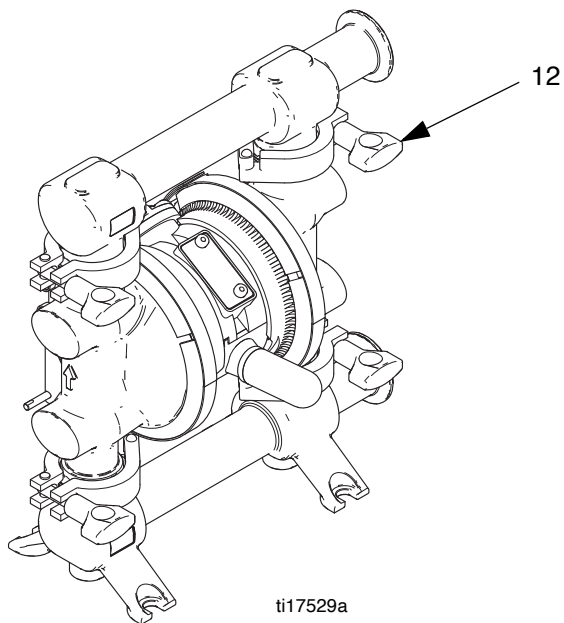





FIG. 3: Reverse the Manifolds

Air Exhaust Ventilation

						
---	---	---	--	--	--	--

To avoid serious injury from explosion or hazardous fluids:

- be sure the system is properly ventilated for your type of installation.
- vent the exhaust away from people, animals, food handling areas, and all sources of ignition
- place an appropriate container at the end of the air exhaust line to catch fluid. If a diaphragm ruptures, the fluid being pumped will exhaust with the air. See FIG. 4.

The air exhaust port is 3/8 npt(f). Do not restrict the air exhaust port. Excessive exhaust restriction can cause erratic pump operation.

To provide a remote exhaust:

1. Remove the muffler (P) from the pump air exhaust port.
2. Install a grounded air exhaust hose (T) and connect the muffler (P) to the other end of the hose. The minimum size for the air exhaust hose is 9.5 mm (3/8 in.) ID. If a hose longer than 4.57 m (15 ft) is required, use a larger diameter hose. Avoid sharp bends or kinks in the hose.
3. Place a container (U) at the end of the air exhaust line to catch fluid in case a diaphragm ruptures. See FIG. 4.

Key:

- A Air supply line
- B Bleed-type master air valve (required for pump)
- C Air regulator
- D Air line quick disconnect
- E Master air valve (for accessories)
- P Muffler
- T Grounded air exhaust hose
- U Container for remote air exhaust

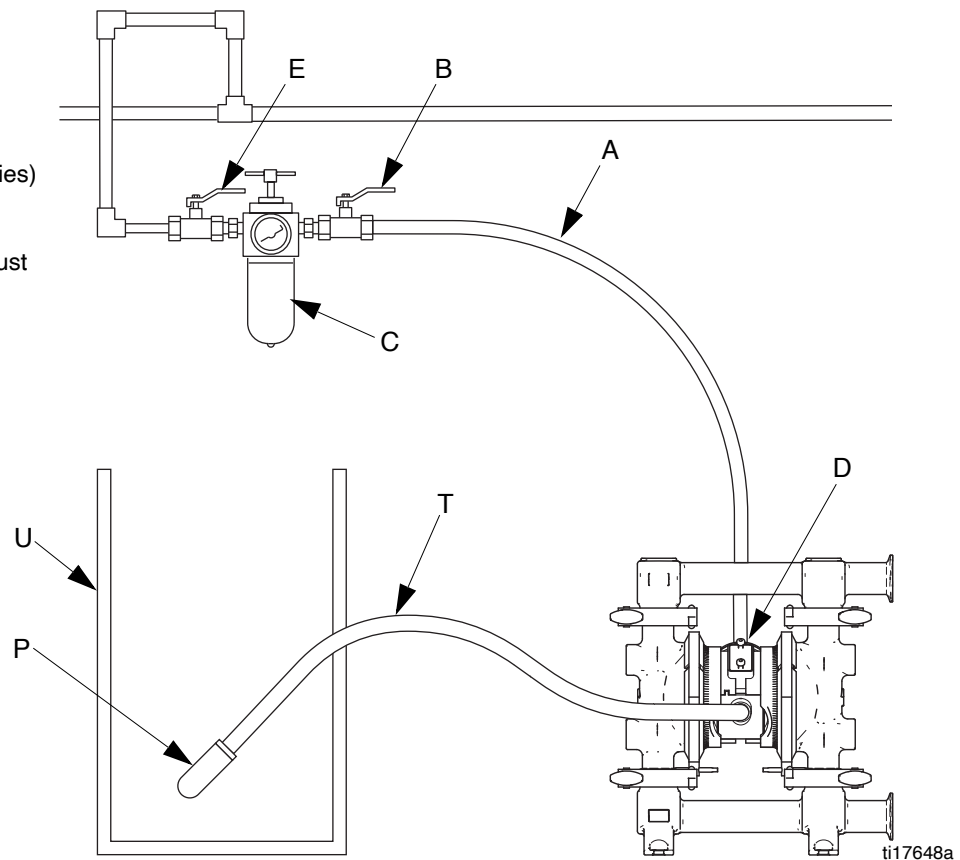

FIG. 4: Venting Exhaust Air

Operation

Pressure Relief Procedure



Follow the Pressure Relief Procedure whenever you see this symbol.



The equipment stays pressurized until pressure is manually relieved. To reduce the risk of serious injury from pressurized fluid or splashing fluid, follow this procedure whenever you stop pumping and before cleaning, checking, or servicing equipment.

1. Shut off the air to the pump.
2. Open the dispensing valve, if used.
3. Open the fluid drain valve to relieve fluid pressure. Have a container ready to catch the drainage.

Sanitize the Pump Before First Use

It is the user's responsibility to properly sanitize the pump before first use. As necessary, follow the steps under **Starting and Adjusting the Pump**, at right, under **Flushing** on page 12, or under **Disassembly** in the **Service** section, starting on page 16.

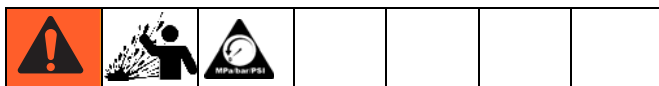

To avoid serious injury from splashing fluid, never move or lift a pump under pressure. If dropped, the fluid section may rupture. Always follow the **Pressure Relief Procedure** before lifting the pump.

Starting and Adjusting the Pump

1. Be sure the pump is properly grounded. Refer to **Grounding** on page 6.
2. Check connections to be sure they are tight. Tighten fluid inlet and outlet connections securely.
3. Connect suction line (F) to material supply.

NOTE: If fluid inlet pressure to the pump is more than 25% of outlet working pressure, the ball check valves will not close fast enough, resulting in inefficient pump operation.

4. Place the end of fluid hose (J) into an appropriate container.
5. Close the fluid drain valve (G).
6. Back out the air regulator (C) knob, and open all bleed-type master air valves (B, E).
7. If the fluid hose has a dispensing device, hold it open while continuing with the following step.
8. Slowly increase air pressure with the air regulator (C) until the pump starts to cycle. Allow the pump to cycle slowly until all air is pushed out of the lines and the pump is primed.

Pump Shutdown

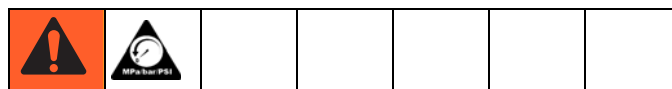

At the end of the work shift, follow the **Pressure Relief Procedure**.

Maintenance

Air Valve Lubrication

The air valve is designed to operate unlubricated, however if lubrication is desired, every 500 hours of operation (or monthly) remove the hose from the pump air inlet and add two drops of machine oil to the air inlet.

NOTICE
Do not over-lubricate the pump. Oil is exhausted through the muffler and could contaminate your fluid supply or other equipment. Excessive lubrication also can cause the pump to malfunction.

Flushing



Insert suction tube into cleaning solution. Open air regulator to supply low pressure air to the pump. Run the pump long enough to thoroughly clean the pump and hoses. Close the air regulator. Remove the suction tube from the cleaning solution and drain pump. Place suction tube in the fluid to be pumped.

Flush the pump often enough to prevent the fluid you are pumping from drying or freezing in the pump and damaging it. Flushing schedule will be based on what the pump is being used for. Use a compatible cleaning solution and always cycle the pump during the entire flushing process.

Always flush the pump and follow the **Pressure Relief Procedure**, page 11, before storing it for any length of time.

Tightening Connections

Before each use, check all hoses for wear or damage, and replace as necessary. Check to be sure all connections are tight and leak-free.

Preventive Maintenance Schedule

Establish a preventive maintenance schedule, based on the pump's service history. This is especially important for prevention of spills, leakage, or food contamination due to diaphragm failure. Inspect all diaphragms for damage at every cleaning.

Troubleshooting



1. Follow the **Pressure Relief Procedure**, page 11.
2. Check all possible problems and causes before disassembling the pump.

PROBLEM	CAUSE	SOLUTION
Pump will not cycle, or cycles once and stops.	Air valve is stuck or dirty.	Disassemble and clean air valve. See page 14. Use filtered air.
	Check valve ball is severely worn and wedged in seat or manifold.	Replace ball and seat. See page 16.
Pump cycles at stall or fails to hold pressure at stall.	Worn check valve balls, seats, or o-rings.	Replace. See page 16.
	Check valve ball wedged in seat.	Repair or replace. See page 16.
	Worn diaphragm shaft seals.	Replace. See page 16 (standard diaphragms).
Pump operates erratically.	Clogged suction line.	Inspect; clear.
	Sticky or leaking check valve balls.	Clean or replace. See page 16.
	Diaphragm ruptured.	Replace. See page 16 (standard diaphragms) or page 18 (overmolded diaphragms).
	Restricted exhaust.	Remove restriction.
Air bubbles in fluid.	Suction line is loose.	Tighten.
	Diaphragm ruptured.	Replace. See page 16 (standard diaphragms) or page 18 (overmolded diaphragms).
	Loose inlet manifold, damaged seal between manifold and seat, or damaged manifold o-rings.	Tighten manifold clamps, or replace seats or o-rings. See page 16.
	Loose diaphragm shaft bolt or fluid side diaphragm plates.	Tighten or replace. See page 16 (standard diaphragms).
Fluid in exhaust air.	Diaphragm ruptured.	Replace. See page 16 (standard diaphragms) or page 18 (overmolded diaphragms).
	Loose diaphragm shaft bolt or fluid side diaphragm plates.	Tighten. See page 16 (standard diaphragms).
	Worn diaphragm shaft seals.	Replace. See page 16 (standard diaphragms).
Pump exhausts air from clamps.	Loose manifolds, damaged seal between manifold and seat, or damaged manifold o-rings.	Tighten manifold clamps, or replace seats or o-rings. See page 16.
	Air valve o-ring is damaged.	Inspect; replace. See page 14.
Pump leaks fluid from check valves.	Worn or damaged check valve o-ring.	Inspect; replace. See page 16.
No fluid output, and pump cycles rapidly.	Pump mounted incorrectly.	Mount the pump in the upright position.
Pump leaks air through the exhaust port.	Worn air valve u-cups.	Inspect; replace. See page 14.

Service

Air Valve

NOTE: Air Valve Repair Kit 819.0662 is available. Parts included in the kit are marked †. Use all parts in the kit.



1. Follow the **Pressure Relief Procedure**, page 11.
2. Remove the air chamber cover (110) and the o-ring (104).
3. Remove the carriage plungers (107), carriages (108), carriage pins (109), and valve plate (114) from the center housing (111).
4. Remove the u-cups (102) from the carriage plungers (107).
5. Clean all parts and inspect them for wear or damage.

NOTE: When instructed to lubricate, apply appropriate waterproof sanitary lubricant.

6. Lubricate the lapped surface of the valve plate (114), and install with the lapped surface facing up.
7. Lubricate and install the carriage pins (109).
8. Install the carriages (108). Make sure the carriages engage the clip ends of the carriage pins (109).
9. Lubricate the bores of the center housing (111), then install the u-cups (102) on the carriage plungers (107), **with the u-cups facing toward smaller end**.
10. Slide the carriage plungers into the bores, **with the smaller ends facing toward the center of the center housing (111)**. See FIG. 5.
11. Lubricate and install the o-ring (104) on the cover (110).
12. Screw the cover (110) into the center housing.

Note: The center housing may remain assembled to the air and fluid covers for this service.

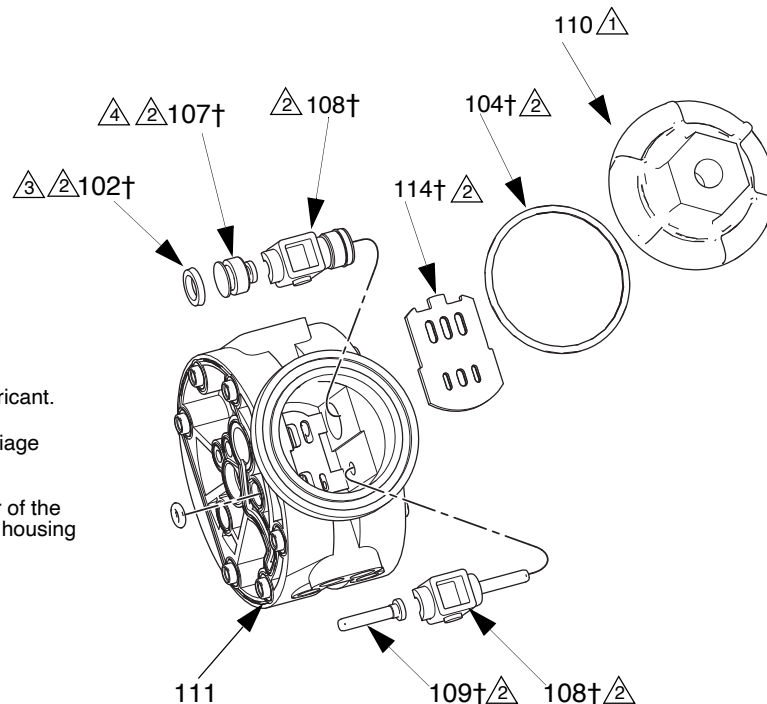

- ① Torque to 9.0-13.6 N•m. (80-100 in-lb).
- ② Apply appropriate waterproof sanitary lubricant.
- ③ Lips must face the smaller end of the carriage plunger.
- ④ Smaller ends must face toward the center of the center housing. Lubricate bores of center housing before installing.

ti17557a

FIG. 5. Disassemble/Reassemble the Air Valve

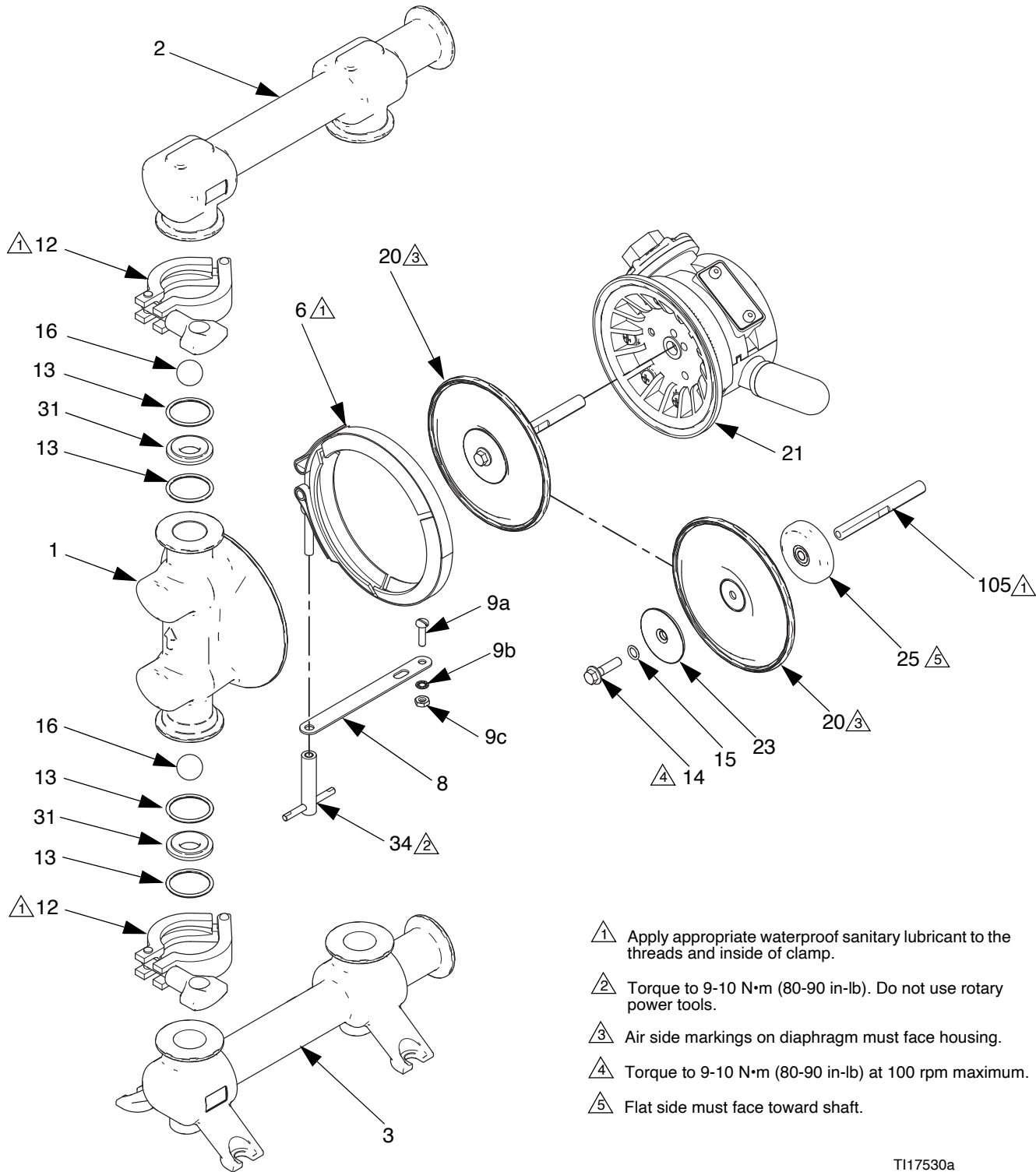

TI17530a

FIG. 6: Disassemble/Reassemble the Pump

Ball Check Valve

Disassembly

NOTE:

- PTFE o-rings should be replaced every time manifolds are removed.



1. Follow the **Pressure Relief Procedure**, page 11. Disconnect all hoses.
2. Remove the pump from its mounting.
3. Remove the clamps (12) holding the outlet manifold (2) to the fluid covers (1). See FIG. 6.
4. Remove the o-rings (13), seats (31), and balls (16).
5. Remove the clamps (12) and the inlet manifold (3). Remove the o-rings (13), seats (31), and balls (16).

Reassembly

NOTE: When instructed to lubricate, apply appropriate waterproof sanitary lubricant.

1. Clean all parts and inspect for wear or damage. Replace parts as needed.
2. Reassemble in the reverse order, following all notes in FIG. 6, page 15. Be sure the ball checks and manifolds are assembled **exactly** as shown. The arrows (A) on the fluid covers (1) **must** point toward the outlet manifold (2).

Standard Diaphragms

NOTE: If your pump uses overmolded PTFE diaphragms, see page 18.

Disassembly



1. Follow the **Pressure Relief Procedure**, page 11.
2. Remove the manifolds and disassemble the ball check valves as explained at left.
3. Remove the nuts (34) and the grounding strip (8), then remove the clamps (6) holding the fluid covers (1) to the air covers (21). Pull the fluid covers (1) off the pump. See FIG. 6.
4. Loosen but do not remove the diaphragm shaft bolts (14), using a 10 mm socket wrench on both bolts.
5. Unscrew one bolt from the diaphragm shaft (105) and remove the o-ring (15), fluid side diaphragm plate (23), diaphragm (20), backer (24) used only on PTFE models, and air side diaphragm plate (25). See FIG. 7.
6. Pull the other diaphragm assembly and the diaphragm shaft (105) out of the center housing. Hold the shaft flats with a 19 mm open end wrench, and remove the bolt (14) from the shaft. Disassemble the remaining diaphragm assembly.
7. Clean all parts and replace as needed.

Reassembly

NOTE: When instructed to grease, apply appropriate waterproof sanitary lubricant.

1. Install the diaphragm assembly on one end of the shaft (105) as follows:
 - a. Install the o-ring (15) on the shaft bolt (14).
 - b. Install the fluid side diaphragm plate (23) on the bolt so the rounded side faces the diaphragm (20).
 - c. Install the diaphragm (20). Make certain the side marked AIR SIDE faces the center housing.
 - d. On PTFE models only, install the backer on the bolt. Make certain the side marked AIR SIDE faces the center housing.
 - e. Install the air side diaphragm plate (25) so the rounded side faces the diaphragm (20).
 - f. Screw the bolt into the shaft (105) hand tight.
2. Grease the length and ends of the diaphragm shaft (105), and slide it through the housing.
3. Assemble the other diaphragm assembly to the shaft as explained in step 1.
4. Hold one shaft bolt (14) with a wrench and torque the other bolt to 9-10 N•m (80-90 in-lb) at 100 rpm maximum.

NOTE: When you install the clamps in Step 5, orient the center housing so the air inlet is approximately 45° above horizontal and the muffler is approximately horizontal.

5. Position the fluid covers (1) and the center housing so the arrows (A) on the covers face the same direction. See FIG. 7. Apply appropriate, waterproof sanitary lubricant and install the clamps around the fluid and air covers. Install the grounding strip on the clamps, and torque the t-handle nuts to 9-10 N•m (80-90 in-lb). Do not use rotary power tools.
6. Reassemble the ball check valves and manifolds as explained on page 16.

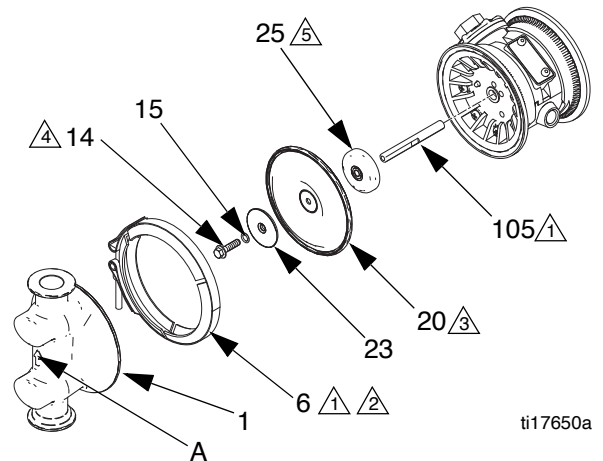

- ① Apply appropriate waterproof sanitary lubricant to the threads and inside of clamp.
- ② Torque to 9-10 N•m (80-90 in-lb). Do not use rotary power tools.
- ③ Air side markings on diaphragm must face housing.
- ④ Torque to 9-10 N•m (80-90 in-lb) at 100 rpm maximum.
- ⑤ Flat side must face toward shaft.

FIG. 7: Standard Diaphragm

Overmolded PTFE Diaphragms

NOTE: If your pump uses standard diaphragms, see page 16.

Disassembly



1. Follow the **Pressure Relief Procedure**, page 11.
2. Remove the manifolds and disassemble the ball check valves as explained on page 16.
3. Remove the clamps (6) holding the fluid covers (1) to the air covers (21). Pull the fluid covers (1) off the pump. See FIG. 8.
4. Once the fluid covers are removed, the diaphragm on the side of the pump which was last pressurized with air will be separated from the center section/air cover. This allows you to grip the diaphragms.
5. Diaphragms are assembled handtight. To loosen, grip both diaphragms securely around the outer edge and rotate counterclockwise. One diaphragm assembly will come free and the other will remain attached to the shaft. Remove the freed diaphragm (20) and air side plate (25).
6. Pull the opposite diaphragm assembly and shaft (105) out of the center housing. Hold the shaft flats with a 19 mm open end wrench and remove the diaphragm and air side plate from the shaft.
7. Clean all parts and replace as needed.

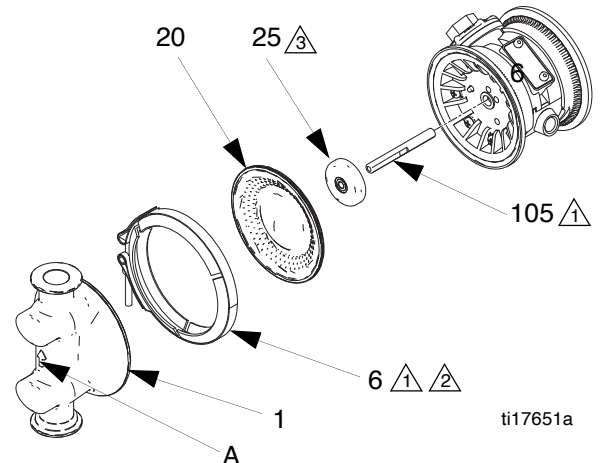

△1 Apply appropriate waterproof sanitary lubricant to the threads and inside of clamp.

△2 Torque to 9-10 N·m (80-90 in-lb).

△3 Flat side must face toward shaft.

FIG. 8: Overmolded PTFE Diaphragm

Reassembly

NOTE: When instructed to grease, apply appropriate waterproof sanitary lubricant.

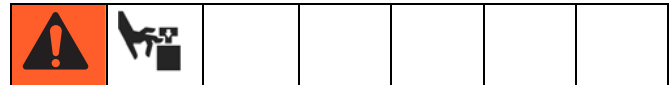

To reduce the risk of serious injury, including amputation, do not put your fingers or hand between the air cover and the diaphragm.

1. Assemble the air side plate (25) onto the diaphragm (20). The wide, radiused side of the plate must face the diaphragm. Screw the assembly (diaphragm and plate) onto the shaft (105) hand tight.
2. Grease the length and ends of the diaphragm shaft (105). Insert the shaft/diaphragm assembly into one side of the pump.
3. Assemble the other diaphragm assembly to the shaft as explained in Step 1.
4. Push the assembly down on the work surface to raise the diaphragm up and out so the edges can be gripped. Hand tighten the second diaphragm onto the shaft.

NOTE: When you install the clamps in Step 5, orient the center housing so the air inlet is approximately 45° above horizontal and the muffler is approximately horizontal.

5. Position the fluid covers (1) and the center housing so the arrows (A) on the covers face the same direction. See FIG. 8. Apply appropriate, waterproof sanitary lubricant and install the clamps around the fluid and air covers. Install the grounding strip on the clamps, and torque the t-handle nuts to 9-10 N•m (80-90 in-lb). Do not use rotary power tools.
6. Reassemble the ball check valves and manifolds as explained on page 14.

Air Center Service

Remove air covers for easier replacement of u-cups and to replace the poppet o-ring, if needed. See parts illustration, page 20.

NOTE: When instructed to grease, apply appropriate waterproof sanitary lubricant.

1. Follow all disassembly directions for diaphragm service. See **Standard Diaphragms**, page 16, or **Overmolded PTFE Diaphragms**, page 18.
2. Remove the muffler (103).
3. Use a phillip's screwdriver to remove 6 screws (22), and remove one air cover (21) and gasket (112).
4. Remove u-cup (102) and poppet o-ring (101).
5. Lubricate and install new u-cup (102) and poppet o-ring (101). U-cup lips must face out of center housing.
6. Reinstall the gasket (112) and air cover (21). Torque screws (22) to 4-5 N•m (35-45 in-lb).
7. Repeat for other side.
8. Reinstall the muffler (103).
9. Follow all reassembly directions for diaphragm service. See page 17 for standard diaphragms or page 18 for overmolded diaphragms.

Parts

Tri-clamp Model Shown

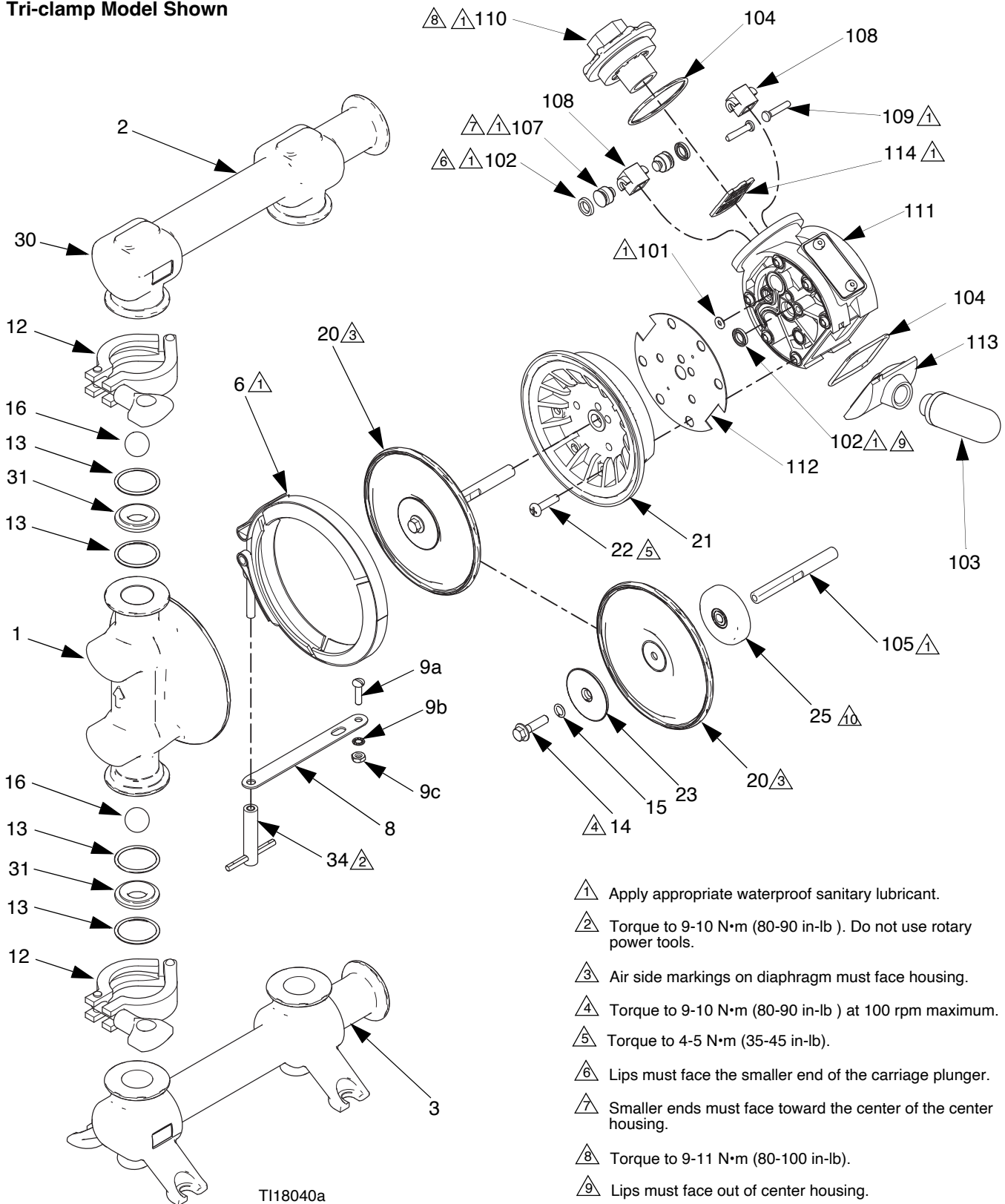

TI18040a

- ① Apply appropriate waterproof sanitary lubricant.
- ② Torque to 9-10 N•m (80-90 in-lb) . Do not use rotary power tools.
- ③ Air side markings on diaphragm must face housing.
- ④ Torque to 9-10 N•m (80-90 in-lb) at 100 rpm maximum.
- ⑤ Torque to 4-5 N•m (35-45 in-lb).
- ⑥ Lips must face the smaller end of the carriage plunger.
- ⑦ Smaller ends must face toward the center of the center housing.
- ⑧ Torque to 9-11 N•m (80-100 in-lb).
- ⑨ Lips must face out of center housing.
- ⑩ Flat side must face toward shaft.

Ref.	Part	Description	Qty
1	819.0501	COVER, fluid	2
2	819.0500 819.0616	MANIFOLD, outlet Tri-clamp models DIN models	1
3	819.0499 819.0615	MANIFOLD, inlet Tri-clamp models DIN models	1
4	819.5968	PLATE, identification, not shown	1
6	819.0487	CLAMP, vee; includes t-handle nut (Ref. 34)	2
8	819.0470	STRIP, grounding	1
9	819.0576	KIT, ground fasteners, stainless steel; includes Refs. 9a, 9b, and 9c	
9a	-----	SCREW, phillips head, #10-24 x 0.75	1
9b	-----	WASHER, #10, flat	1
9c	-----	NUT, #10-24 x 0.125	1
12	819.0440	CLAMP, sanitary, 1.5 in.; Qty. 2	2
13*	----- ----- -----	O-RING PTFE EPDM	8
14	819.0436 819.0562	SCREW, 1/4-20 x 1 Hex head flange (for standard diaphragms); Qty. 2 Socket head set (for overmolded diaphragms); Qty. 2	1 1
15*	819.0424	O-RING (not used with overmolded diaphragms); Qty. 2	1
16*	819.0435 819.0421	BALL Santoprene; Qty. 4 PTFE, Qty. 4	1
17	819.0425	RIVET, pop, not shown; Qty. 2	1
19	819.0486	AIR MOTOR, <i>see Air Motor Parts</i>	1
20*	859.0298 859.0299 859.0300	DIAPHRAGM KIT, Qty. 2 Santoprene; includes Refs. 13 and 15 PTFE; includes Refs. 13, 15, and 24 Overmolded PTFE; includes Refs. 13 and 14	1
21	819.0502	COVER, air	2
22	819.0438	SCREW, phillips, pan head #12-14 x 7/8; Qty. 12	1
23	819.0564	PLATE, diaphragm, fluid side (not used with overmolded diaphragms)	2

Ref.	Part	Description	Qty
24*	819.0561	DIAPHRAGM, TPE backup; Qty. 2	1
25	819.0476	PLATE, diaphragm, air side For use with standard diaphragms	2
	819.0563	For use with overmolded diaphragms	
30 ▲	819.6311	LABEL, warning (not shown)	1
31	819.0577	KIT, seats, ball check, Qty. 4	1
34	-----	NUT, t-handle; included with vee clamp (Ref. 6)	2

Air Motor Parts

Ref.	Part	Description	Qty
101*	819.0437	O-RING; Qty. 2	1
102†*	819.0423	U-CUP; Qty. 4	1
103	819.0434	MUFFLER	1
104†*	819.0442	O-RING; included with exhaust cover (Ref. 113) and air chamber cover (Ref. 110); Qty. 2	1
105	819.0473	SHAFT	1
107†	819.0558	PLUNGER, carriage; Qty. 2; includes 2 u-cups (Ref. 102)	1
108†	819.0471	CARRIAGE; Qty. 2	1
109†	819.0472	PIN, carriage; Qty. 2	1
110	819.0489	COVER, air chamber; includes o-ring (Ref. 104)	1
111	-----	HOUSING, center	1
112*	819.0474	GASKET; Qty. 2	1
113	819.0488	COVER, exhaust; includes o-ring (Ref. 104)	1
114†	819.0475	PLATE, valve	1

* These parts are included the Fluid Section Repair Kit, sold separately. See page 22 for the correct kit for your model. Use appropriate waterproof sanitary lubricant.

† These parts are included in Air Valve Repair Kit 819.0662, sold separately. Use appropriate waterproof sanitary lubricant.

▲ Replacement Warning labels, signs, tags, and cards are available at no cost.

----- These parts are not sold separately.

Fluid Section Repair Kits*

Pump Model	Repair Kit	Includes:
810.0824 or 810.0825	819.0609	2 PTFE o-rings (15), 4 PTFE balls (16), 4 FKM u-cups (102), 2 TPE diaphragm backers (24), 8 PTFE o-rings (13), 2 PTFE diaphragms (20), 2 FKM o-rings (101), 1 buna-n o-rings (104), 2 gaskets (112), 1 anaerobic adhesive
810.0826 or 810.0827	819.0610	2 PTFE o-rings (15), 4 PTFE balls (16), 4 FKM u-cups (102), 2 PTFE/EPDM overmolded diaphragms (20), 8 PTFE o-rings (13), 2 FKM o-rings (101), 1 buna-n o-rings (104), 2 gaskets (112), 1 set screw, 1 anaerobic adhesive
810.0828 or 810.0829	819.0614	2 PTFE o-rings (15), 4 Santoprene balls (16), 4 FKM u-cups (102), 2 Santoprene diaphragms (20), 8 EPDM o-rings (13), 2 FKM o-rings (101), 1 buna-n o-rings (104), 2 gaskets (112), 1 anaerobic adhesive

* Use appropriate waterproof sanitary lubricant.

Dimensions

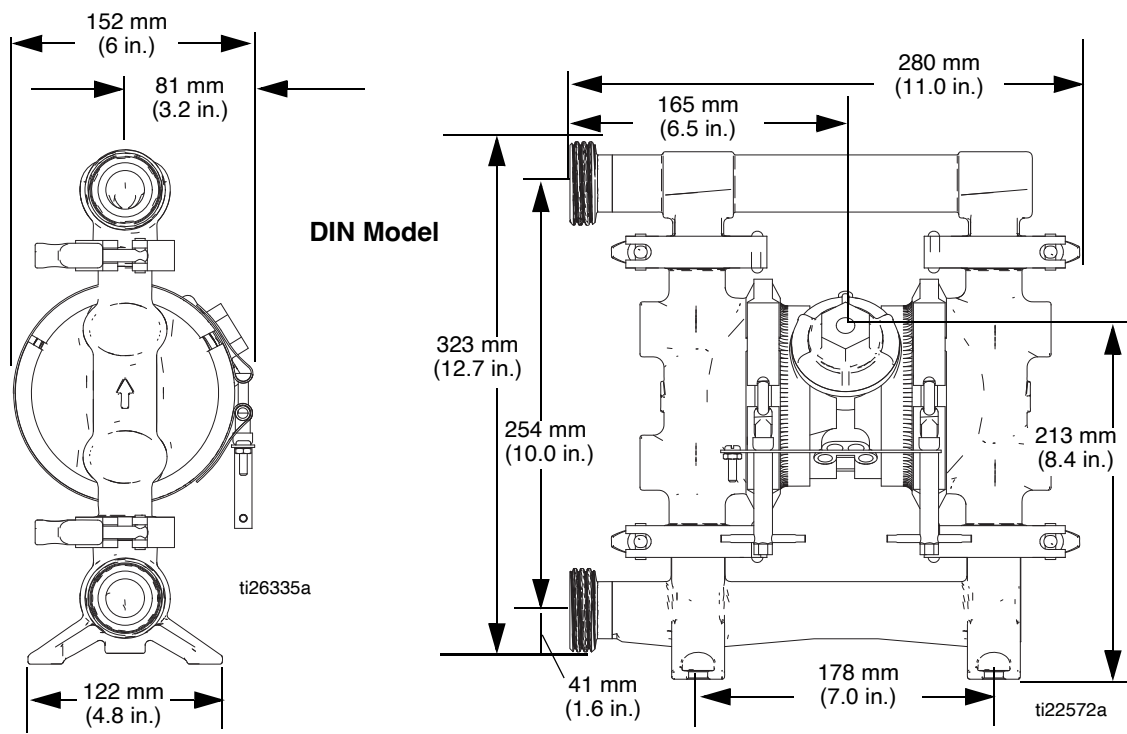
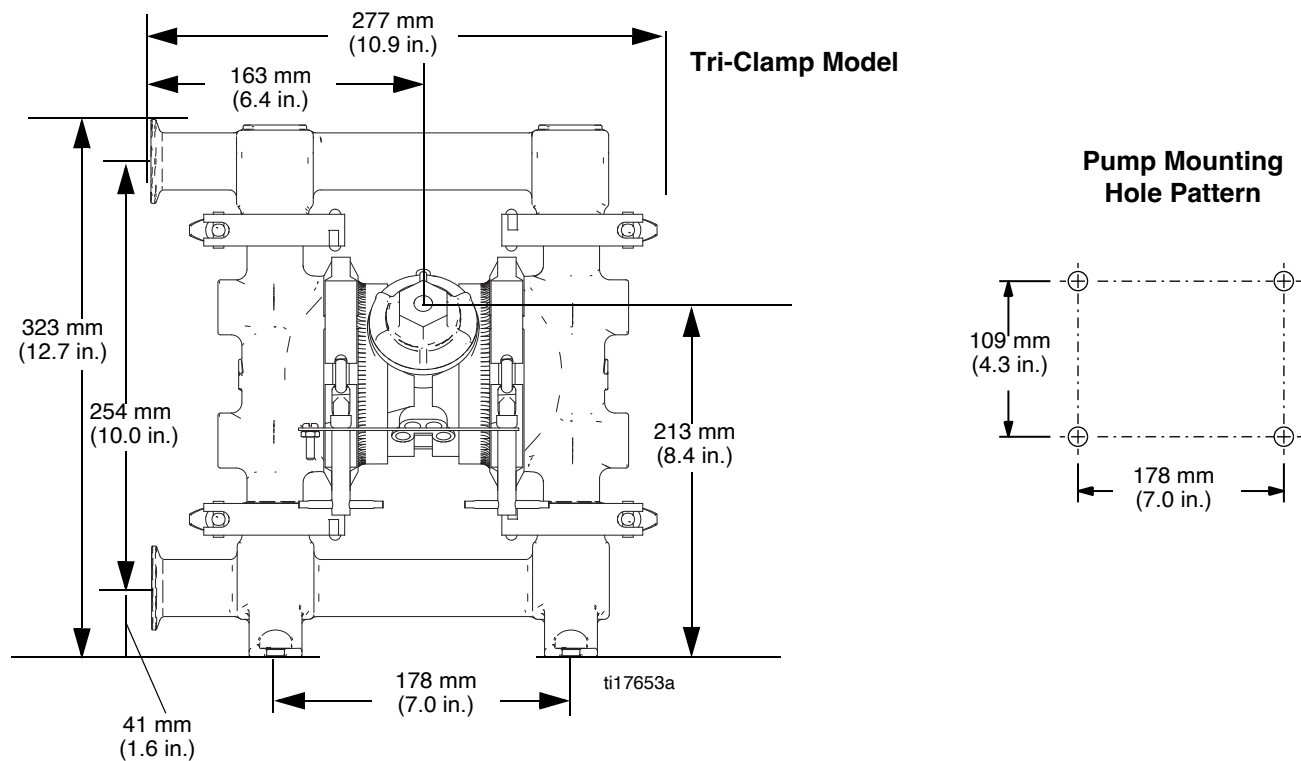

Performance Charts

Fluid Outlet Pressure

Test Conditions: Pump tested in water with inlet submerged.

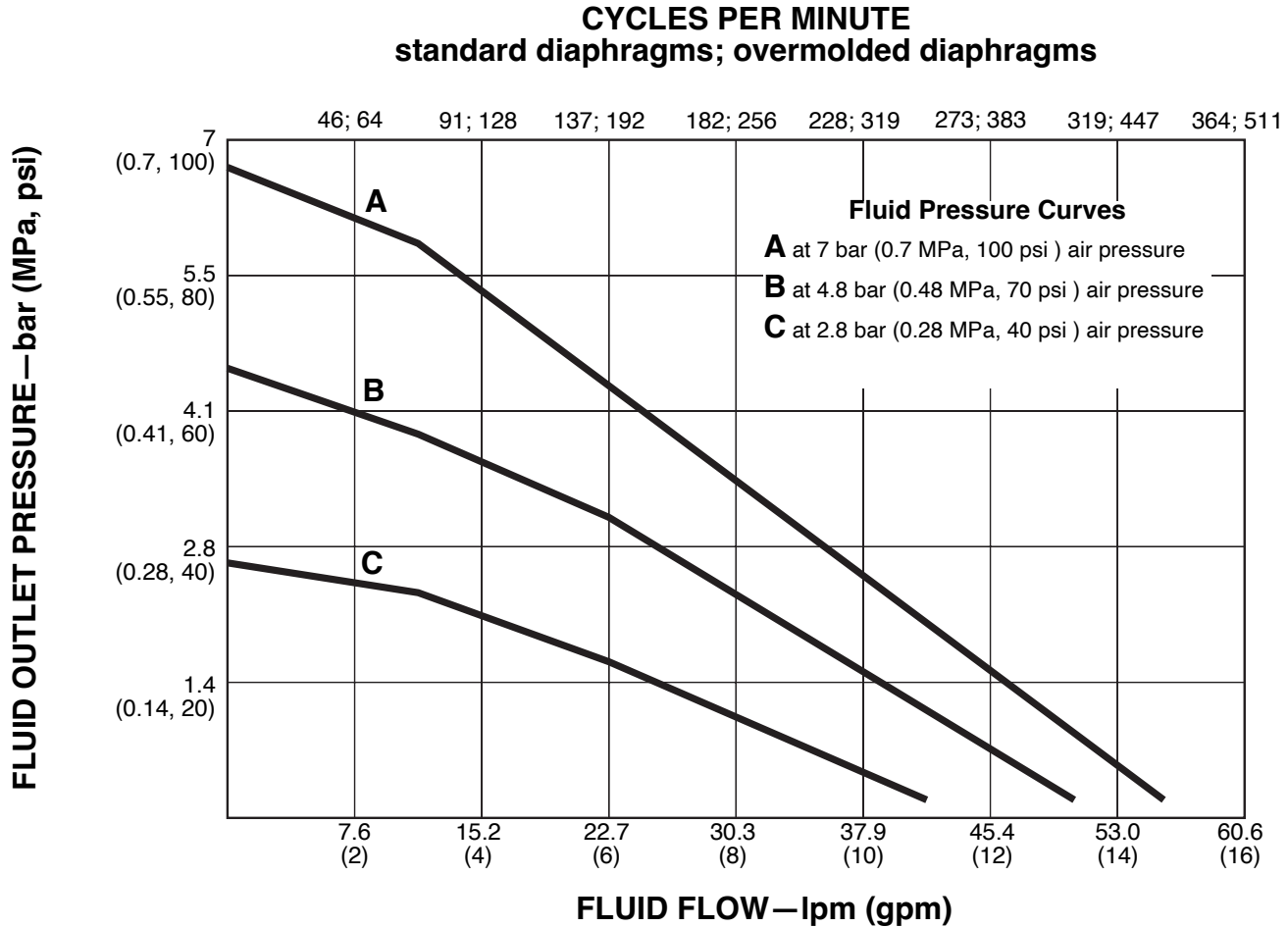

To find Fluid Outlet Pressure (bar/MPa/psi) at a specific fluid flow (lpm/gpm) and operating air pressure (bar/MPa/psi):

1. Locate fluid flow rate along bottom of chart.
2. Follow vertical line up to intersection with selected fluid outlet pressure curve.
3. Follow left to scale to read fluid outlet pressure.

Air Consumption

Test Conditions: Pump tested in water with inlet submerged.

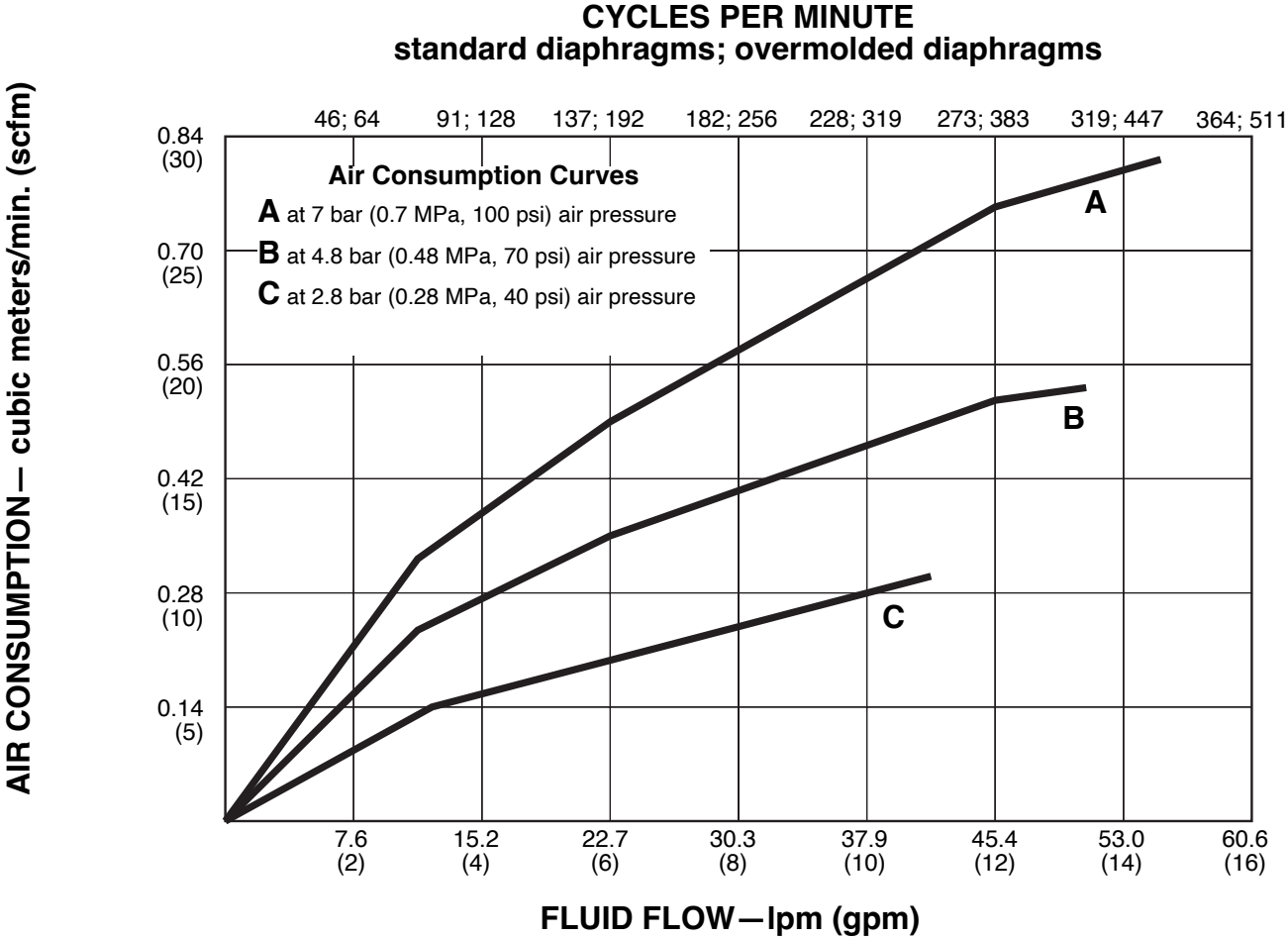

To find Pump Air Consumption (m^3/min or scfm) at a specific fluid flow (lpm/gpm) and operating air pressure (bar/MPa/psi):

1. Locate fluid flow rate along bottom of chart.
2. Follow vertical line up to intersection with selected air consumption curve.
3. Follow left to scale to read air consumption.

Technical Data

Verder VA-H 20		
	US	Metric
Maximum fluid working pressure	100 psi	0.7 MPa, 7 bar
Air pressure operating range*	20-100 psi	0.14-0.7 MPa, 1.4-7 bar
Maximum air consumption	28 scfm	0.8 m ³ /minute
Air consumption at 70 psi/20 gpm	18 scfm	0.5 m ³ /minute
Maximum free-flow delivery	16 gpm	60 l/min
Maximum recommended cycle rate for continuous duty	182 cycles per minute	
Maximum size pumpable solids	3/32 in.	2.4 mm
Maximum viscosity	10,000 cps	
Environmental temperature range	40°–120°F	4°–49°C
Minimum fluid temperature	40°F	4°C
Maximum fluid operating temperature (Do not exceed the lowest maximum depending on the diaphragm, ball, and seat used in your pump.)		
PTFE	220°F	104.4°C
Santoprene®	180°F	82.2°C
EPDM	275°F	135°C
Maximum suction lift		
Dry	15 ft.	4.6 meters
Wet	25 ft.	7.6 meters
Maximum pump speed		
Standard Diaphragms	400 cycles per minute	
Overmolded Diaphragms	500 cycles per minute	
Fluid flow per cycle*		
Standard Diaphragms	0.04 gallons	0.15 liters
Overmolded Diaphragms	0.03 gallons	0.11 liters
Noise (dBa)		
Maximum sound pressure	78 dBa @ 70 psi (0.48 MPa, 4.8 bar)	
Inlet/Outlet Sizes		
Air inlet size	1/4 in. npt(f)	
Air exhaust port size	3/8 npt(f)	
Fluid inlet size	1 in. sanitary flange or 25 mm DIN 11851	
Fluid outlet size	1 in. sanitary flange or 25 mm DIN 11851	

Materials of Construction**		
Wetted materials on all models	316 SST	
Wetted material depending on model	EPDM, PTFE, Santoprene® (CAUTION: Santoprene® may be used only with non-fatty, non-oily foods or alcohols up to 15%.)	
Non-wetted external parts	300 series stainless steel, FDA-compliant polypropylene, polyester (labels)	
Weight		
All models	23 lb.	10 kg
Notes		
<p>* <i>Startup pressures and displacement per cycle may vary based on suction condition, discharge head, air pressure, and fluid type.</i></p> <p>** <i>All fluid contact materials are FDA-compliant and meet the United States Code of Federal Regulations (CFR) Title 21 for repeated use in food-processing machinery. The pump user must verify that the construction materials meet their specific application requirements.</i></p> <p><i>Santoprene® is a registered trademark of the Monsanto Co</i></p>		