

HOSOKAWA ALPINE Aktiengesellschaft

P.O. Box 10 11 51

86001 Augsburg, Germany

Delivery address:

Peter-Doerfler-Strasse 13 – 25

86199 Augsburg, Germany

Tel.: + 49 821 5906-0

Fax: + 49 821 5906-101

E-mail: mail@alpine.hosokawa.com

www.alpinehosokawa.com

Subject to change without notice.
All information in this brochure is
purely informative and non-binding.
Our quotations are authoritative with
regard to orders.

CONTRAPLEX® PIN MILLS

TYPE 160 C TO 1120 CW



HOSOKAWA ALPINE Aktiengesellschaft

Hosokawa Alpine is a member of the Hosokawa Micron Group, a high-performance manufacturer of systems for powder and particle processing, systems for the confectionery industry as well as plastics processing machines and systems. The group is known and reputed the world over for its power of innovation, constant product care and market-oriented R&D. The most important group resources are R&D, engineering and manufacturing as well as customer service in all global markets.

© Hosokawa Alpine 2009. Printed in Germany.



HOSOKAWA ALPINE

PROCESS TECHNOLOGIES FOR TOMORROWSM



Contraplex wide-chamber mills the proven system when it comes to solving even the most challenging comminution tasks.

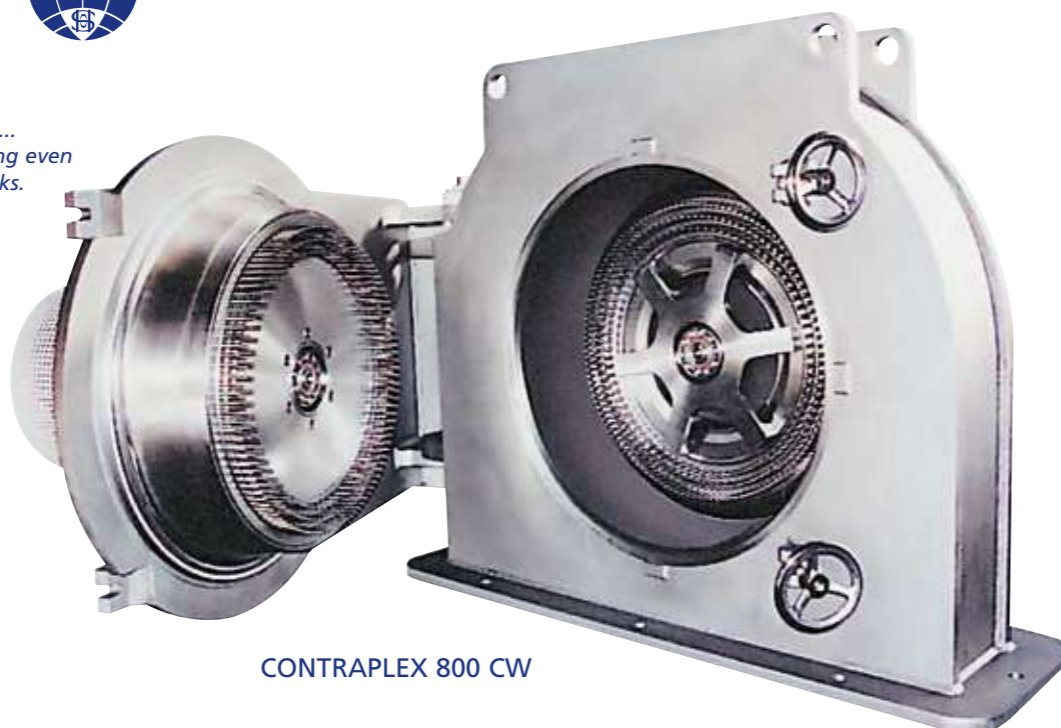

CONTRAPLEX 800 CW

PRINCIPLE OF OPERATION

The Contraplex is a fine impact mill with two driven pin discs. In counter-rotating mode, much higher relative speeds are possible than with the UPZ fine impact mill which has only one driven pin disc. The highest relative speed develops at the outermost pin rows and can be up to 250 m/s. The feed material should be brittle with a maximum Mohs' hardness of 3. The fineness can be adjusted by altering the pin disc speeds. The centrifugal forces acting on both discs ensure that even moist, greasy and sticky products can be processed. The design with the wide-chamber housing is ideal for processing

these kinds of products. The feed material is often embrittled by intensive mixing with liquid nitrogen. The mill door can be opened wide to permit easy cleaning. Dependent on the machine size, product feed is either from the front through the machine door or from the rear of the mill housing.

Product line Contraplex Type		160 C	250 CW	400 CW	630 C	800 CW	1120 CW
Scale-up factor F		0.4	1	2.5	5	11	22
Drive (housing side)	kW	7.5	15	37	55	132	250
Speed (housing side)	rpm	16500	11200	8400	3550	3000	2250
Pin rows		3	3	3	2	3	3
Drive (door side)	kW	5.5	7.5	22	55	132	250
Speed (door side)	rpm	12000	5600	4500	3150	2800	2000
Pin rows		2	3	3	3	3	3
Total air flow rate	max. m ³ /h	-	1000	2400	4400	8200	23000
Total weight w/o drive motors and feed unit	approx. kg	900	900	1000	1400	4000	5000

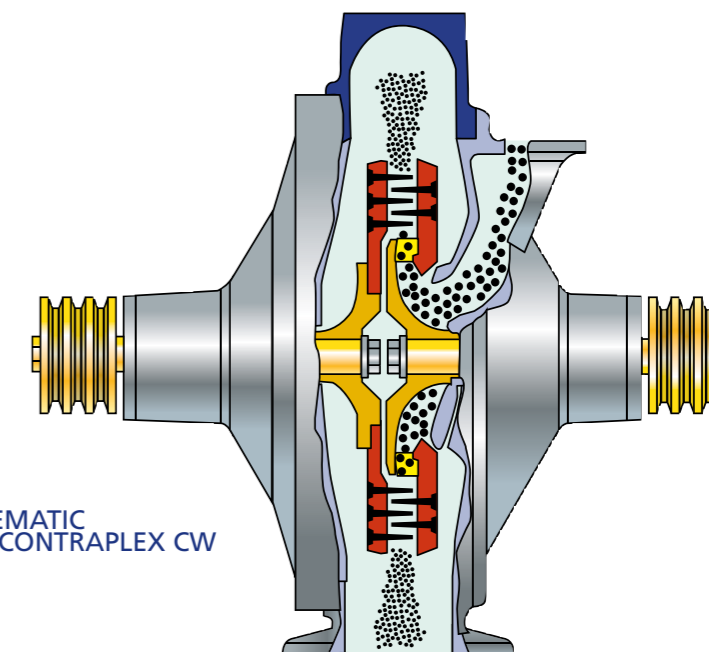

SCHEMATIC CONTRAPLEX CW

FEATURES

- The CW wide-chamber housing prevents coating formation and thus blockages in the machine.

In comparison with the pin disc Ø, the machine housing is oversized. This is why Contraplex mills are ideal for fine grinding greasy, oily, sticky and hygroscopic materials which tend to form deposits - either in continuous mode or at relatively long cleaning intervals. Besides the wide-chamber housing, the rotation of both pin rows (both speed and rotational direction are adjustable) is a distinguishing feature. The following important application advantages result:

- Wide selection of pins

Besides the standard head pin made of special steel, there is a wide selection of special pins available which make it possible to meet the highest demands regarding hygiene as well as freedom from wear and contamination.

- Robust drive solution

The belt drive via standard motors permits optimum configuration of the transmission ratio for the process and the product. This means that the motor and pin disc work

at the optimum operating point and the system achieves a much higher degree of energy efficiency than with direct drives.

- Bearing unit

The optimum monitoring of bearing temperature and vibrations translates into excellent preventative maintenance.

- Higher grinding fineness

Dependent on the type, the max. relative speed of both discs is up to approx. 250 m/s. Single-rotor pin, beater, cross-flow and turbo mills, etc. are unable to reach this high speed. The Contraplex therefore produces higher grinding fineness values - especially with all brittle and crystalline materials.

- Individual adaptation of the grinding conditions to suit the feed material

The wealth of possibilities available in setting the rotational direction and disc speed combinations ensures that each and every product - especially heat-sensitive ones - is ground to an optimal fineness, is handled gently and that the pin discs remain free from deposits.

- Intensive, agglomerate-free and homogeneous mixing-grinding of products

that consist of two or more components (food technology).

- Trouble-free continuous operation

Products which cannot be ground in sieve mills due to their tendency to clog the sieve perforations - especially fine-mesh sieves - can be ground to high fineness values.

Rinsing air protects the bearing unit from product ingress and prevents product from depositing behind the pin discs.





DESIGNS

- Welded housing with either standard or tangential discharge
- Mild steel or stainless steel (e.g. 1.4541, 1.4571, 1.4404) for all machine sizes
- Pin discs and pins made of special steel
- Cast housing with standard discharge available for machine sizes 250 to 630
- Bearing unit protected against dust by air rinsing (automatic air intake or forced rinsing)
- Bearing unit permanently lubricated or designed for relubrication
- Safety interlock
- Option: pharma design
- Option: wear-proof pins
- Option: explosion-pressure-shock-proof design for a max. explosion overpressure of 10 bar (g) with type test certificate as defined in the ATEX Directive 94/9/EC

TYPE 160 C
FOR CRYOGENIC GRINDING



TYPE 250 CW WITH
WIDE-CHAMBER HOUSING



TYPE 400 CW
APPLICATION EXAMPLE:
MAGNESIUM SULPHATE

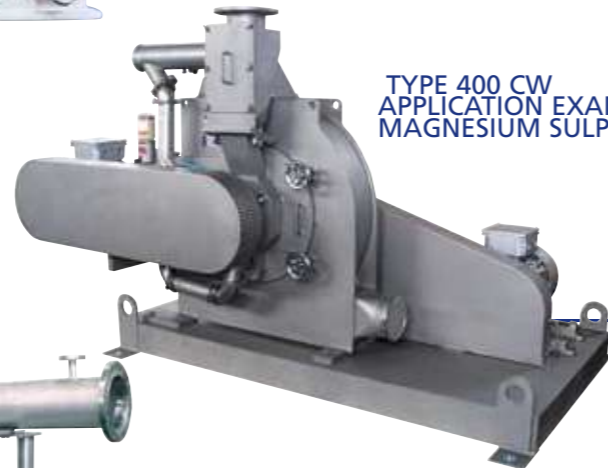

TYPE 630 C
APPLICATION EXAMPLE:
POLYSTYRENE

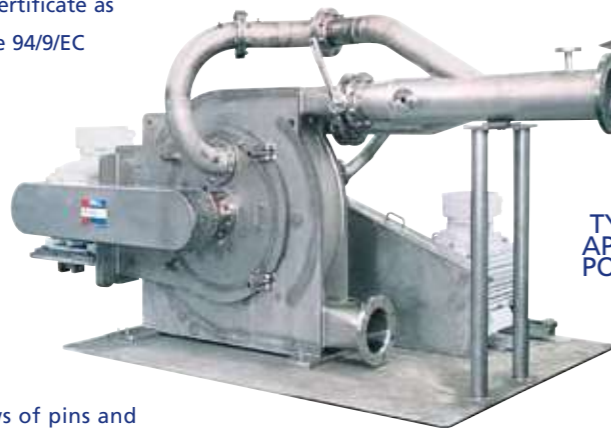

The closely intermeshing rows of pins and the optimally coordinated pin length and distribution guarantee superior grinding results. In extreme cases, the adaptation to difficult feed materials is accomplished by varying the construction material of the pins as well as the number and configuration of pins.



TYPE 800 CW
STAINLESS STEEL DESIGN
APPLICATION EXAMPLE: FOOD

160 C

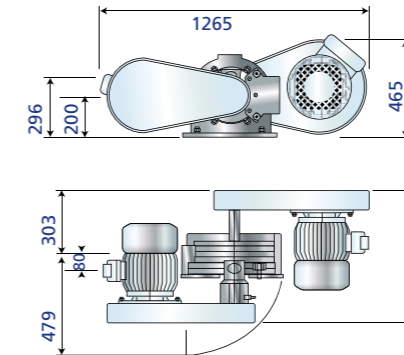

800 CW

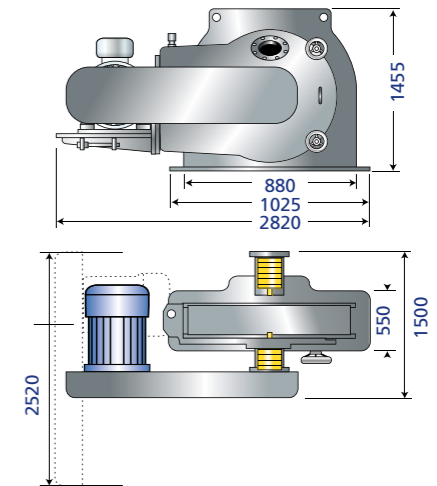

250 CW; 400 CW

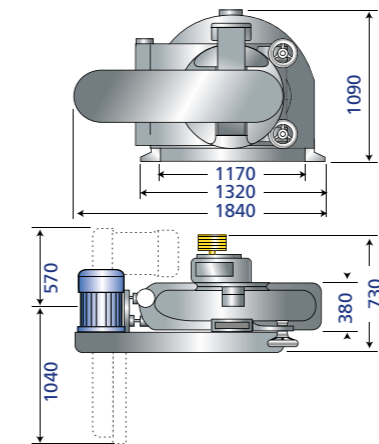

1120 CW

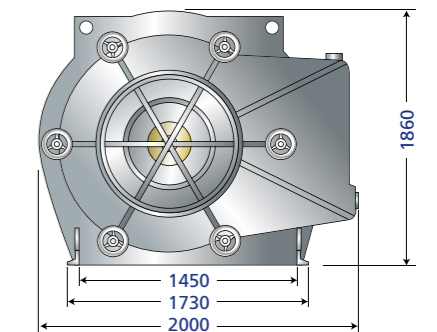

630 C

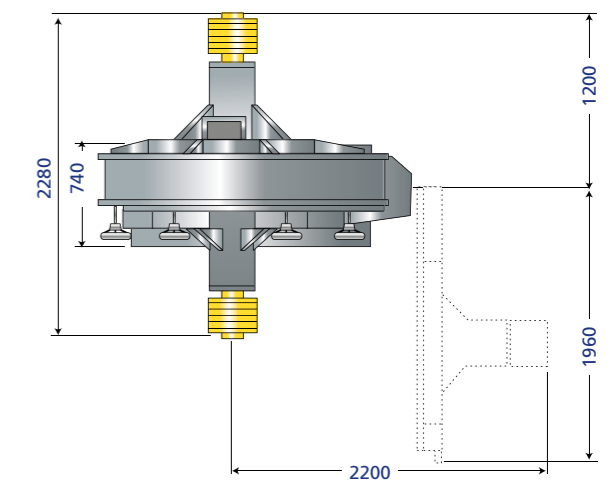
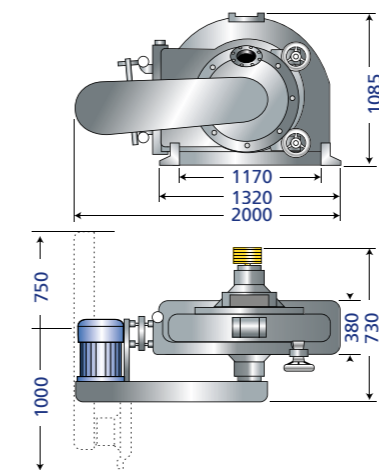



Many materials need to be available in ground form before they can be further processed or used. Some of these products, however - for example, thermoplastics, elastomers, wax, varnish additives and also some metals - are not easy to grind at ambient temperature because they are viscous and elastic. Over and above this, there is the risk of oxidation and as a result, of subsequent dust explosion.

that are two to three times higher than normal as well as high particle fineness values.

Cryogenic grinding makes it possible to execute processes at high stressing speeds and short stressing cycles.



The example shows the particle size distributions of SBR/NR rubber granules ground with an impact mill.

The graph plots a direct comparison between the grinding results of a cryogenic grinding process and those of a grinding process at ambient temperature. The d_{50} value was improved from approx. 480 μm to 180 μm .

Dependent on the grinding process, the nitrogen consumption is between 0.7 and 1.2 kg of LN_2 /kg of product.

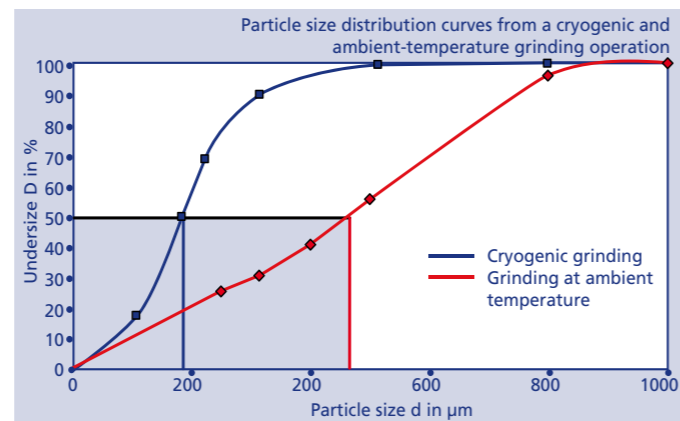

Practical examples and consumption figures: Contraplex 250 CW

Product	Temperature °C	Throughput kg/h	Nitrogen consumption LN ₂ kg/kg	Fineness % < μm					
				50 μm	80 μm	100 μm	160 μm	200 μm	500 μm
PP + PE	+20	200	0.75	7	12	15	30	40	85
Epoxy resin	-2	420	0.3	85	92	96	-	-	-
Polyamide	-50	196	1.65	-	55	-	-	93	-
Cellulose ester	-45	176	1.35	13	30	45	75	90	-
Rubber granules	-30	300	0.9	-	-	8	20	30	88
PES/PUR	-40	275	1.2	-	16	19	44	61	98
Polyethylene	-40	230	1.5	-	12	17	42	56	99
EVA	-30	250	1.0	8	18	25	75	97	-
Polypropylene	-50	100	1.8	5	12	22	52	72	99
Polyurethane	-50	140	2.1	6	20	28	56	66	99



Cryogenic grinding prevents spices from heating up during grinding and causing the essential oils to volatilise and heat-sensitive fats to melt. In the worst case, this can lead to the grinding elements clogging up and the mill blocking. Cryogenic grinding therefore optimises both the product properties and the process management.

It is possible with cryogenic grinding to improve the aroma by reducing the loss of essential oils (approx. 3 - 10% loss) in comparison to grinding at ambient temperature (approx. 15 - 43% loss). Over and above this, the level of grinding performance is twice as high and the fire hazard eliminated.

The cooling agents predominantly used are CO_2 and LN_2 . The product and the system are either cooled by direct injection of the cooling agent into the mill or, if longer residence times or lower temperatures are necessary, by means of pre-cooling and material embrittlement with a screw cooler.

Essential oil content in comparison *

Spice	Original material		Normal grinding		Cryo. grinding LN ₂	
	v/g (= ml/100g)	%	v/g	%	v/g	%
Mace	16.1	100	9.10	56.5	14.5	90.0
Cloves	17.3	100	11.5	66.5	16.5	95.4
Pepper, white	3.38	100	1.95	57.7	3.19	94.4
Pepper, black	3.37	100	2.21	65.6	3.09	91.7
Pimento	3.19	100	2.71	85.0	3.08	96.6

* Comparison : retention of the essential oil by cryogenic grinding



CW CRYOGENIC GRINDING SYSTEM IN CIRCUIT-GAS MODE WITH LN₂

Enthalpy	CO_2	330 kJ/kg (-20°C)
Enthalpy	LN_2	363 kJ/kg (-20°C)

- 1 Feed metering unit: channel, screw, rotary valve, etc.
- 2 Screw cooler with LN_2 supply
- 3 Contraplex CW impact mill
- 4 Automatic filter, often in quick-change design
- T Temperature sensor

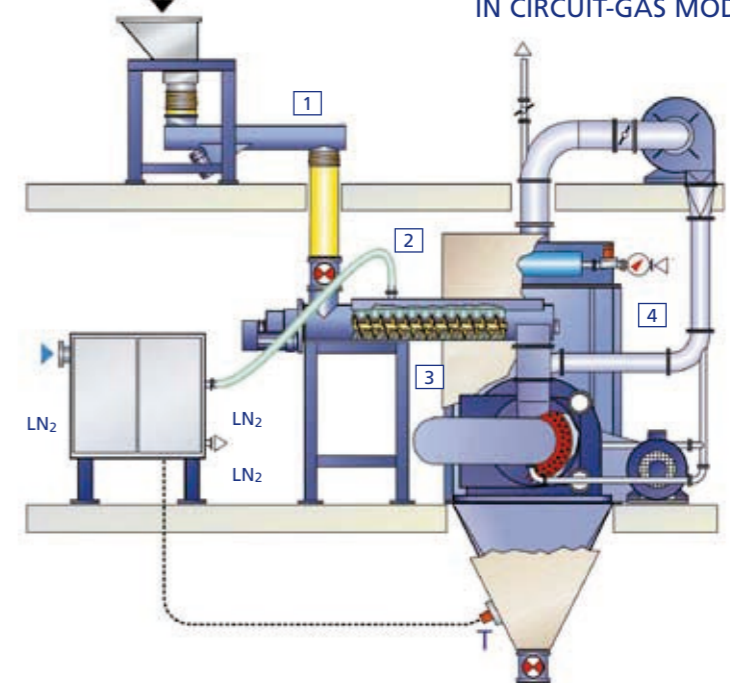



Spice grinding is one of the most difficult comminution tasks

Both the structure of spices and their grindability vary greatly. The quality of some spices such as turmeric, for example, can differ significantly dependent on the planting method and time of harvesting.

FINE GRINDING WITH THE CONTRAPLEX CW

Because of their universality in use, especially for extremely greasy and heat-sensitive spices which cannot be handled by other systems, Contraplex mills are reputed in the trade to be the classic spice mills. Continuous operation over long periods of time is possible, even with extremely difficult spice types that pose technical grinding problems.

The speed and rotational direction of both pin discs can be selected to ensure "gentle" grinding with maximum retention of the essential oils, even when high grinding fineness values are demanded.

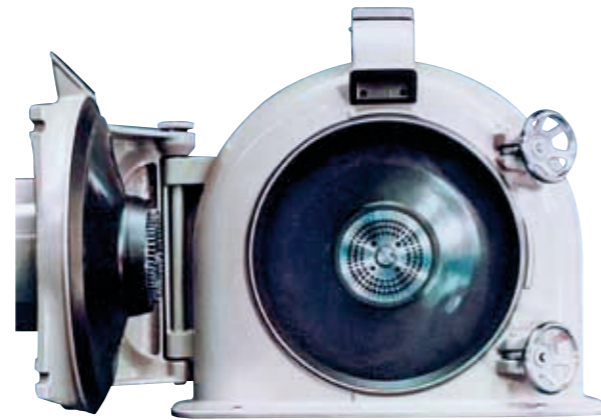

CONTRAPLEX PIN MILL 250 CW

Practical examples, type 250 CW

Spice	Approx. capacity kg/h	Approx. fineness 95% < μm
Aniseed (seeds)	100 - 150	1000 μm
Chilies (whole pods)	120 - 200	500 μm
Fennel (seeds)	200	1500 μm
Cardamom	100	600 μm
Coriander	200	630 μm
Caraway	100 - 250	700 μm
Nutmeg	300 - 700	1200 μm
	200 - 500	800 μm
	200 - 400	600 μm
Cloves	70 - 150	630 μm
	250	850 μm
Paprika	200 - 400	400 μm
Pepper	300 - 400	500 μm
Pimento	150	500 μm
Mustard seeds	500	630 μm
	400	400 μm
Star aniseed	400	250 μm
Juniper berries	250 - 450	1500 μm
Cinammon	150	200 μm

GUIDE VALUES FOR GRINDING AT AMBIENT TEMPERATURE

Due to the strong contrast in grindability, the values given for spices are merely reference values. Moisture content, purity, the content of essential oils as well as the origin of the spices all play a role.



COATING MINERAL POWDERS

Contraplex pin mills have long been successfully employed for the surface treatment of mineral powders. The most frequent application is coating finely ground natural calcium carbonate powder ($d_{97} = 2$ to $20 \mu\text{m}$) with stearic acid. Besides this, talc and kaolin are also coated, whereby it is mostly silanes that are used here for the surface treatment.

Such surface-coated minerals are able to form a permanent bond between the mineral powder and a plastic. The resultant surface-treated fillers are used not only, e.g. in plastic window profiles, PVC pipes and automobile parts as fillers, but are also valued for their improved properties, for example, the impact strength.

All-important for the quality when coating calcium carbonate are the temperature



TYPE 630 C APPLICATION: COATING

control during the entire process and the constant supply of coating agent (0.5 to 2%) and mineral powder. A special melting unit for coating agents made it possible to optimise the process even further. The molten coating agent is sprayed through a two-component nozzle and blended with the mineral powder in a primary bin. Thanks to the intensive mixing in the Contraplex



COATED MINERAL POWDER IN WATER

pin mill and the temperature management, an excellent coating quality is achieved. The system is operated using a modern PLC control unit with visualisation.

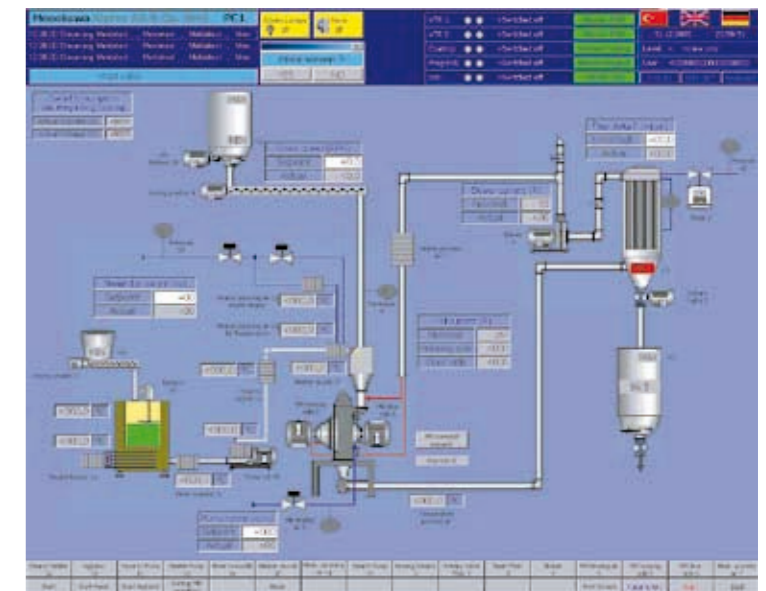



The more challenging the task, the more you profit from our wide range of services:



CONSULTING SERVICES

Problem specification, exploration of different technical solutions, product-specific processes, consideration of safety aspects, different system concepts, e.g. pressure-shock-proof, inert gas mode, CIP/SIP, etc.

TRIALS

Grinding and classifying trials, laboratory analyses, determination of energy requirements and production costs, manufacture of product samples, rental systems.

ENGINEERING

Initial design stage:
conceptual studies - basic engineering, flowcharts - installation planning; safety concepts, e.g. ATEX; project documentation
Detail planning:
P&I diagrams; calculation and layout; specification of components; design, programming and networking of visualisation systems; structural steel engineering with static calculations; planning the piping and ductwork; official acceptance of subcontractor work.

PROCESS AUTOMATION

Control cabinets, conventional control units (Plexwire), process control with PLC, visualisation systems, process data archiving, logic diagrams, teleservice connection for remote maintenance.

DOCUMENTATION

- Operating instructions, operating manuals
- "As built" documentation
- Software documentation
- Documentation as per 21 CFR Part 11 for the pharmaceuticals industry
- CE certification

MANUFACTURING

Areas of competence:

- CNC autogenous and plasma flame cutting.
- Manufacture of pressureless and pressure-shock-proof welding subassemblies of differing material quality by qualified machinists and welders.
- CNC processing of complex components for film blowing systems and pharma machines using turning, drilling, milling and grinding.

ASSEMBLY

- Assembly of complicated subassemblies and machines of different design and dimensions.
- Design consultancy in all manufacturing issues.
- Test runs, factory acceptance tests (FAT).

ENGINEERING PLANNING AND SUPERVISION

- Project coordination
- Installation and assembly of complete systems on the customer's premises by competent field service engineers all over in the world
- On-site supervision

COMMISSIONING

- Commissioning, training, test runs, site acceptance tests (SAT).

TOLL GRINDING

Our affiliated company, Hosokawa Micron Powders GmbH in Cologne, offers a wide range of toll processing services. We would be glad to give you the contact details.

MADE IN GERMANY

A high-quality product calls for competence in development, engineering, manufacture and assembly. And this competence in turn stems from the training, know-how, experience and motivation of the company staff. The environment of the company headquarters in Augsburg has always fulfilled these requirements in the best possible way. And it is here that we find the dedicated and excellently trained staff who render a great service to the company, the products and the success of our customers.

For this reason and in the tradition of our own self-imposed commitment to high quality, we will continue to lay store by Germany as a business location. The new emblem for our letterheaded company paper with the message ENGINEERED, MANUFACTURED AND ASSEMBLED IN GERMANY underlines this commitment.

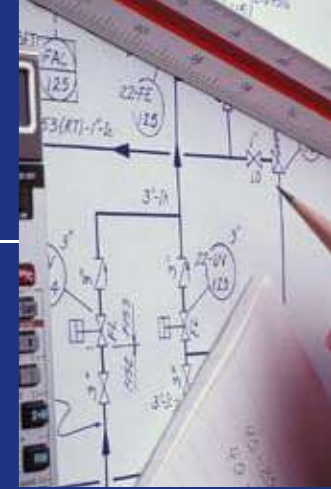

With a floor area of 3000 m² spread over 4 stories, the Hosokawa Alpine application testing centre in Augsburg is one of largest testing centres in Europe dedicated to the wet and dry processing of products in powder form. With over 60 state-of-the-art machines and complete systems on both a production and laboratory/pilot scale as well as the associated testing laboratory, we offer you the most comprehensive range of testing possibilities aimed at optimum system layout and determination of process-related guaranteed values.

The 20-strong team in the testing centre is made up of test engineers, laboratory technicians, system assistants and mechanics, is fully conversant with the technical characteristics of every system and has a great deal of experience in handling a wide variety of different products. Dependent on your project, we offer you the possibility with an Alpine Contraplex 160 C equipped with state-of-the-art process management of grinding, drying, coating, classifying and simultaneously disagglomerating your product.

